

Moving Coil Input Transformer LL1678

LL1678 is an input audio transformer for moving coil pickups. The transformer is built up from two coils, each coil with one secondary winding surrounded by two primary windings. This structure results in an excellent frequency response. All winding ends are available on the pins. Thus, the transformer can be used with a set of different turn's ratios.

The LL1678 is made with amorphous core material. As this type of core does not store energy (unlike e.g. conventional mu-metal cores) the low frequency resonance with external series capacitors is practically eliminated.

Turns ratio:

1 + 1 + 1 + 1 : 16 + 16

Dims: (Length x Width x Height above PCB (mm))

30 x 22.5 x 14.5

Pin Layout (viewed from pins side) and windings schematics:

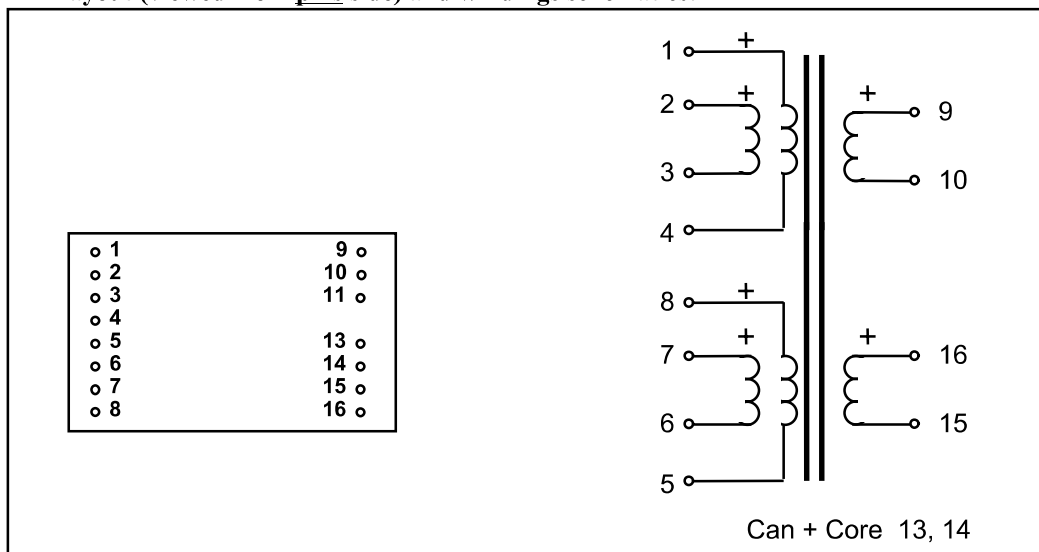

Spacing between pins:	Spacing between rows of pins:	Rec. PCB hole diameter:	Weight:
2.54 mm (0.1")	22.86 mm (0.9")	1.5 mm	27 g

Static resistance of each primary (average):	4.5 Ω
Static resistance of each secondary:	375 Ω
Frequency response (primary signal level -17 dBu [0.1Vrms], Termination alternative A. Source 50Ω , load 100 kΩ) :	
Balanced/unbalanced input. Balanced output	10 Hz -- 90 kHz +/- 1 dB
Balanced/unbalanced input. Unbalanced output	10 Hz -- 35 kHz +/- 1 dB
Distortion (primaries connected in series, source impedance 50Ω) :	< 0.5% @ -8 dBu, 50 Hz
Primary no load impedance @ 0 dBu, 50 Hz, all in series:	8 kΩ typically
Core / Can:	Amorphous Strip Core / Mu metal can
Isolation between windings / between windings and core:	3 kV / 1.5 kV

Turns ratio and possible use at different termination alternatives. Termination alternatives are shown on the next page			
Termination Alternative	Turns ratio	Copper Resistance prim/sec	Possible Use
A	1:8	18Ω / 750 Ω	150Ω / 10 kΩ
B	1:8	4.5Ω / 190 Ω	Not recommended
C	1:16	4.5Ω / 790 Ω	25Ω / 10kΩ
D	1:16	1.1Ω / 190 Ω	Not recommended
E	1:32	1.1Ω / 790 Ω	10Ω / 10kΩ

When the LL1678 is used in MC pickup applications, please note that the primary side of the transformer must have a ground reference.

LL1678 Termination Alternatives

(Left side is input if not stated otherwise)
(Pins side view)

